

**Operating Manual for
Escher Wyss Cooling Towers
Series EWK, EWB and MODUPOL**

R 2.312 A - 07.2002_E

Table of Contents	Page
1. Introduction	2
2. General Description	2
3. Design Characteristics	2
4. Special Equipment	6
5. Installation	8
6. Start-up	10
7. Maintenance schedule	11
8. Water quality	13
9. Trouble shooting	14
10. Safety regulations	15
11. Resistance	16
12. Maintenance Works	17

1. Introduction

This operating instruction is published as a guide for installing, operating and maintenance of induced draught industrial cooling towers. Following these guidelines ensures a optimum performance and maximum service life of the equipment.

If the instructions laid down in this guide are not observed, the manufacturer cannot be held responsible in case of damage.

The general conditions of supply of Axima Refrigeration GmbH - which are an integral part of the order confirmation - are respectively effective.

For technical details please refer to our order confirmation.

Subject to technical modifications.

For your kind attention:



This guide is in the first place intended for the operating staff and should always be available. Its contents should be dealt with confidentially.

The copyright remains the property of

Axima Refrigeration GmbH, D-Lindau.

We draw your attention to the fact that it is quite impossible to treat herein all probabilities. This means that the user is not exempted of the usual responsibilities connected with the use of technical machinery. It is, therefore, taken as granted that the operating staff is well instructed and knows how to handle this installation.

No claims whatsoever could be enforced by the contents of this guide.

If the user has no operational manual of his own, all maintenance and repair work could be recorded on page 16 of this guide.

2. General Description

Escher Wyss cooling towers of type EWK, MODUPOL and EWB are mechanical draught series type cooling towers working in counter flow principle.

In this type of cooling tower the water to be cooled is distributed evenly over a packing, which is ventilated from below with air. Within that packing heat-and mass transfer takes place. The partial evaporation of this water reduces the heat from the water circuit and transmit it to the air. Compared to dry coolers, with this type of wet cooling towers a lower water temperature can be achieved even in case of high air temperatures.

3. Design Characteristics

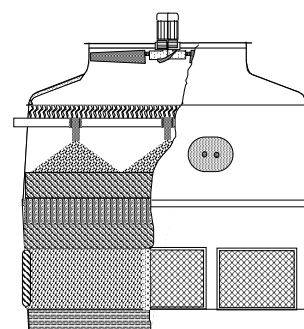

3.1 Casing

3.1.1 EWK Series 036 - 1800

Fig. 1: Series cooling tower with axial fan at suction side, type EWK

The cooling tower casing and the water basin are made of strong corrosion-proof fibreglass reinforced polyester resin. The fan ring is supported by the shell structure of the upper part of the cooling tower. Additional loads through outlet silencers are limited and have to be inquired.

There are inspection hatches for the examination of the spray nozzles.

3.1.2 MODUPOL[®] Series

The MODUPOL[®] type which consists of pre-assembled casing modules is connected with the mechanical part and several substructures.

The casing walls are functionally shaped wall elements internally screwed and sealed.

The external snow and wind load as well as the load caused by the SEWL standard silencers can be transmitted to the foundation through the wall elements, which are equipped with beads.

The fan casing consists of a cylindrical ring of several pieces made of fibreglass reinforced polyester resin. The fan supports are made of galvanized or stainless steel. Erection on site, with fan and fan drive to form the mechanical part.

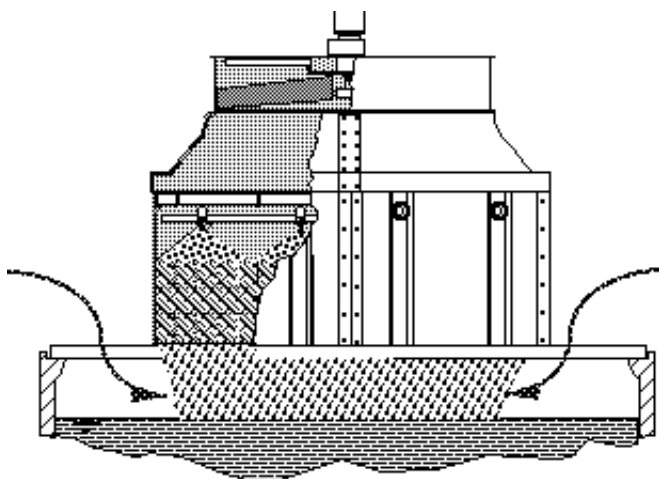

3.1.2.1 Basic Type

Fig. 2: Serial cooling tower with axial fan at suction side, type MODUPOL[®] (schematic)

The basic type is erected on a concrete basin with supporting beams. The dimensions of the concrete basin are greater than the cooling tower foot print. The air intake is effected through the remaining space between cooling tower and the edge of the basin.

3.1.2.2 Basic Type With Air Inlet Frame

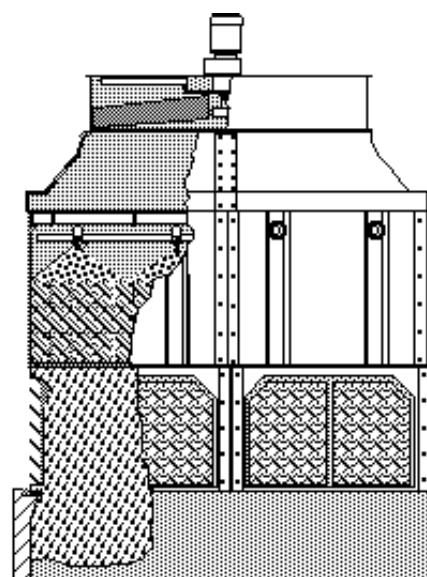

Fig. 3: Series cooling tower with axial fan at suction side, type MODUPOL[®] (schematic)

The frame-substructure is erected on a concrete basin. The basin dimensions correspond to those of the cooling tower foot print and the vertical suction area between the frames is equipped with special louvres.

3.1.2.3 Basic Type With Air Inlet Module

The water basin of fibreglass reinforced polyester resin and the air inlet frame are pre-assembled and can be erected in modular style on a girder foundation.

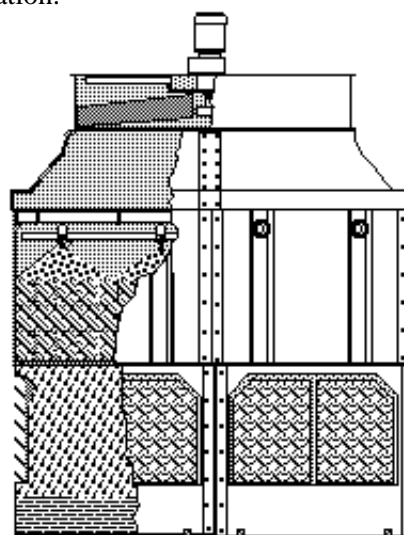

Fig. 4: Serial cooling tower with axial fan at suction side, type MODUPOL[®] (schematic)

3.1.3 EWB Series 1300 - 7200

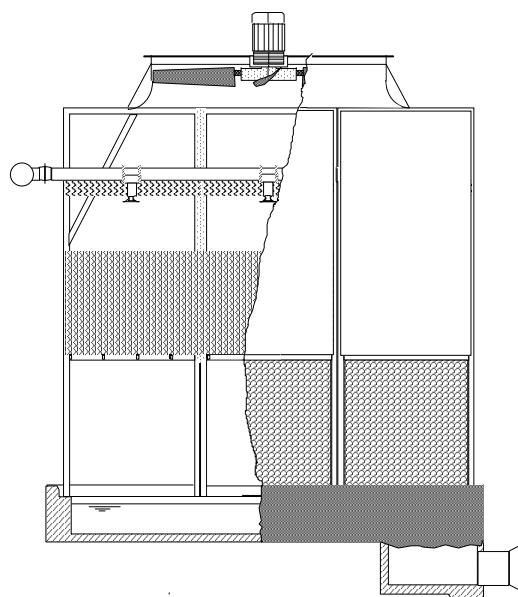

Fig. 5: Series cooling tower with axial fan at suction side, type EWB (schematic)

The supporting structure is made of galvanized steel sectional frame with wall plates of fibreglass reinforced polyester resin. The frames are corrosion-proof as long as the water does not include any zinc attacking components. The wall sheeting is corrosion-proof.

3.2 Hydraulic Device

3.2.1 Water Distribution System

The water flows through the main distribution pipes made of stainless steel to the plastic nozzles. Their arrangement allows an optimum water distribution inside the tower.

3.2.2 Packing

The packing consists of some layers of a high performance cooling tower fill, made of long lasting plastic material. For standard applications a film type fill is build in, splash fill is also available on request.

(Standard :PVC, execution see order confirmation)

3.2.3 Air Inlet Louvres

Lateral winds can blow water out of the cooling tower wetting the surroundings and provoke important water losses. To keep these as low as possible, the cooling tower is equipped with special air inlet louvres which achieve a high separation effect at a low pressure loss.

To allow the adjustment of the float valve and the cleaning of the water basin a louvres package can easily be removed for this purpose.

3.2.4 Drift Eliminator

In order to reduce water losses, a drift eliminator is installed above the water distribution system. It consists of individual packages put side by side. The specially developed profile form brings a low pressure loss and a high eliminating effect.

3.3 Mechanical Device

3.3.1 Fan

Escher Wyss cooling towers of the EWB, EWK and MODUPOL series are equipped with low noise axial fans at suction side. The fan blades are adjustable at standstill.

For cooling towers type EWK 680 ... 1800 fans of the type "C" are used as standard. Cooling towers of the MODUPOL and EWB series are equipped with the fan types "C" or "H1/H2". Select the corresponding fan type from the order documentation. For the types EWK 036 ... 450

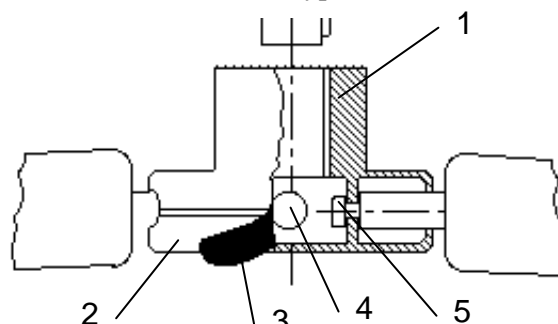

usually the fan type "H1" is used.

3.3.1.1 Axial Fan Type C

Fig. 6: Hub design

- Impeller with patented hub system consisting of two precision machined steel forgings, the first of which **1** is keyed to the output shaft while the second part **2** locks the blades and mates to it.
- Each blade **3** consists of either aluminium alloy or FRP profile which is fixed to a steel shank **4** by a set of bolts.
- The hub end of the shank is grooved **5** to locate and lock the blade to the hub.
- The blades of the fans are individually balanced against a common master blade, thereby, allowing complete interchangeability. The specifications of ISO 1940 part 1 class G 6,3 are fulfilled.

3.3.1.2 Axial Fan Type H1

- Impeller and hub are made of sheet steel, welded and galvanized with hub flanges at the external sheathing **1** (depending on the number 4,5,6 or 8 pieces), which serve as holders of the impeller blades. The hub plate **2** is flanged to

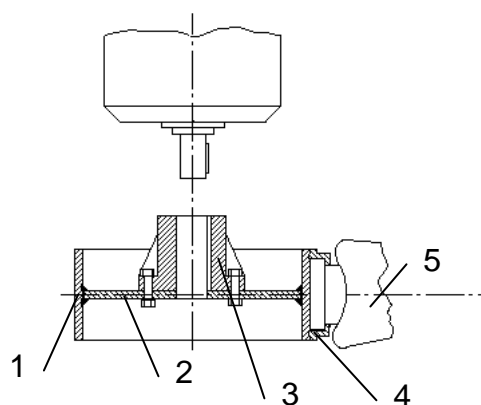

the shaft hub **3**, which fits to the motor shaft.

Fig. 7: Hub design

- The impeller blades **5** with connection flange are made of fibreglass reinforced epoxy resin, fibreglass reinforced polyester resin or aluminium cast alloy.
- The impeller blade **5** is fixed at the hub flange with a two-piece clamping ring. The clamping ring parts have a graduation of 0_i to 30_i which serves for the adjustment of the impeller blades. The grade indication at the clamping ring corresponds to the angle at the utmost profile (nominal diameter).
- The impellers are dynamically balanced and correspond to the balance quality G 6,3 according to ISO 1940 section 1. Under no circumstances remove the counterbalance weights which were fixed during balancing inside the external coating or at the hub flanges.
- If the impeller has to be dismantled for transport reasons, follow the assembly instructions when mounting again.

3.3.1.3 Axial Fan Type H2

Fig. 8: Hub design

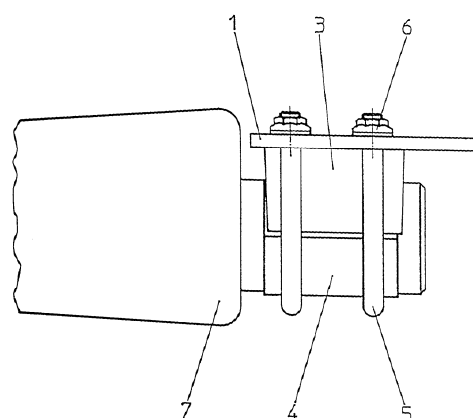

- Impeller with hub plate **1** made of galvanized sheet steel with flanged shaft hub for assembling to the motor shaft. Pillow blocks **3** fixed on the hub plate serve as holding device of the impeller blades **7**.
- The pillow blocks are positioned with clamping pins. The clamping pins must not be removed.
- The impeller blade inserted in the pillow block is fixed by means of a packing **4**, fastening bow **5** and self-locking nut **6**.
- The pillow block is equipped with an exterior graduation for the adjustment of the impeller blades.
- The impellers are dynamically balanced and correspond to the balance quality G 6,3 according to ISO 1940 section 1. Under no circumstances remove the counterbalance weights (they are marked with colours) which were fixed during balancing at the pillow block or hub plate.
- If the impellers are delivered dismantled, regard marking of the parts when mounting again. Follow assembly instructions.

3.3.2 Fan Drive

For smaller cooling towers i.e. type EWK 036É450 the fan drive is carried out with a multi-pole electrical motor. The fans of series EWB and MODUPOL as well as EWK 630É1800 are driven by a helical geared motor.

3.3.2.1 Multi-Pole Motor

The rotational speed of the fan, which is directly mounted to the motor shaft, is given by a corresponding number of pole-pairs. The motors are optimized for this operational conditions therefore they are equipped with additional fins.

3.3.2.2 Geared Motor

Fans with a bigger diameter are directly driven by helical geared motors which prevent vibrations. These fan drives are designed for long lasting operation with high performance. Reserves for switch on and switch over to other rotational speeds are foreseen. Additional load by unbalanced impellers are acceptable when they are in scope of technical standards.

The single stage motors are equipped with 4-poles, two stage motors have 4/8-poles. Corrosion protection includes prime coat and colour coat. The motor is easily accessible for maintenance.

The oil level 1 is in general controlled by an oil measuring stick which is placed and connected with the breather 2. Bleeding the oil off the gearbox can be made using the oil drain 3. The positions of the mentioned means are marked in Fig 9.

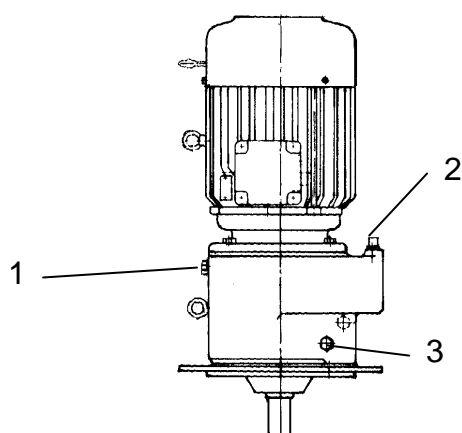

Fig 9: Cooling tower geared motor (sample of a two stage gearbox)

3.4 Strainer Basket

The strainer prevents that coarse impurities enter into the cooling water circuit. It can be installed either in the water basin of the cooling tower or in a separate basin.

For cooling tower series EWK 036É1800 a build in strainer is standard. For series EWB and MODUPOL a strainer basket is available as part of the special equipment.

4. Special Equipment

4.1 Float Valve

A float valve is used for the regulation of the make-up water, it is installed in the cooling tower basin or in a temporary storage bin. The water level has to be regulated in that way that the drain piece is sufficiently covered with water and that whirlpools and air suction can be avoided.

When adjusting the water level it has to be considered that always a small quantity of water flows back into the basin when switching off the cooling tower pump. This water should not drain off through the overflow. The maximum water level must therefore always remain below the overflow level

4.2 Level Control

4.2.1 Electrode Level Control

It is possible to regulate the make-up water inlet by using an electrode level control with solenoid valve, for greater water flow rates with motor valve.

To operate the solenoid or motor valve the following is necessary:

- 1 electrode relay
- 3 electrodes (mass/min./max..)
- 1 terminal box for electrodes' cable

4.2.2 Electrical Float Valve

A solenoid valve or motor valve is controlled by the level of a swimming body on the water surface.

4.2.3 Hydrostatic Level Control

The hydrostatic pressure in the water basin is measured by a capacitive pressure gauge. Its signal can be used for control of solenoid valve or motor valve.

4.3 Frost Protection

To keep the area near run-off pipe ice-free during operation at cold weather conditions an electrical heating is available.

The heating shall be connected according to the wiring diagram of Axima Refrigeration GmbH which is delivered in any case.

The heating must not be switched on, when water level in basin is too low. Overheat protection device is therefore available.

4.4 Fan Thermostats

They serve to switch on or off the fan drives depending on the cold water temperature.

The sensor is preferably placed in the piping for cooled water and should be protected by a threaded sensor cartridge.

The sensor may also be placed in the cooling tower basin but it has to be taken into account that mechanical stress and vibrations to the sensor are avoided.

For precise measurement of the water temperature it is important that sensor is completely covered by the water.

The sensor is delivered as separate part.

4.4.1 One-Stage Fan Thermostat, RT 26

Range -5 to +50 °C. (Can also be used as heating thermostat).

This device is equipped with a switch-over contact. If used as a fan thermostat, connected to terminals 2 and 3, as heating thermostat it should be connected to terminals 2 and 1

It is supplied for the heating control with the temperature setting:

- switching on at 1,0 °C and
- off at 3,5 °C.

If used as a fan thermostat, the required switching points have to be set according to the enclosed directions, for example:

- switching on at 26,0 °C and
- off at 22,0 °C.

The lower temperature has to be set by means of a control button. The switch difference is set on the differential roll. see Fig. 10

The upper response temperature results from the lower response temperature + difference which, for the chosen example is

$$22 + 4 = 26 \text{ °C.}$$

Do not choose a too small switch difference, in order to avoid that motor switches on and off too frequently. The cold water temperature should not be fixed lower than 10 °C.



Fig. 10: One-stage thermostat RT 26

4.4.2 Two-Stage Thermostat, A 28 MA

For two-speed fan motors two-stage thermostats must be used.

This device is fitted with two switch contacts (switch blocks):

- low temperature range, right hand switch block
- high temperature range, left hand switch block.

For fan operation, connect it at the red and white marked terminals respectively. The bridge between the red marked terminals has to be eliminated.

Range +5 +50 °C.

Difference in the stages 3 K, difference between the stages approx. 4 K.

Example:



The switching-on temperature in the first stage (in this case +25 °C) has to be set on the graduation. All other switching points result from the set differences in and between the stages.



If using other thermostat types, the settings and connections have to be carried out according to the corresponding instructions.

Fig. 11: Two-stage thermostat A 28 QA-9101

4.5 Sound Attenuator For Air Discharge

The sound attenuator at the air discharge is carried out as a ring shaped screen element fixed onto the fan supporting ring.

In most cases its absorption factor of the emitted noises by fan and motor is sufficient to reach the required noise level.

The casing is made of fibreglass reinforced polyester and coated inside with sound absorbing PU foam with a waterproof surface.

4.6 Sound Attenuator Air Inlet Side

At the air inlet side, sound attenuator casings of fibreglass reinforced polyester can be adapted. For series EWK 630É1800 the air intake is on top of the casings, for bigger cooling towers the air intake area is vertically, i.e. in parallel to the cooling tower walls.

Sound attenuation is obtained by baffles with moisture resistant absorption material.

4.7 Ladder

Access is possible to fan and drive by using the adapted ladder with back protection, footboard and guardrail.

4.8 Oil Level Control

For control of gearbox oil level a remote control unit is available on request.

4.9 Vibration Control

Vibration control is recommended to prevent damages resulting from unbalanced fan blades

4.10 Water Distribution Pipe

For cooling towers having multiple water pipe connectors a pre distribution device is available to reduce the number of connectors.

5. Installation



5.1 Place Of Installation:

- Installation has to be carried out according to our foundation drawings.
- The place of installation should allow an easy access to all parts of the cooling tower. Free air flow to air inlet and outlet should be given.
- Avoid installation directly at the edge of roofs and near public roads; possibility of mist and ice formation in winter.
- Contact of moist air with walls and buildings should be avoided.
- To keep the cooling water circuit clean as long as possible, do not install the cooling tower near trees or exhaust devices.

5.2 Connection Of The Primary Circuit

- Connect all pipes free of tension.
 -  Outdoor pipes should automatically discharge if pump stops.

5.3 Electric Installation

-  All information given on the wiring diagram supplied with our order confirmation have to be observed. All protective measures have to be carried out according to the safety regulations applicable on site.
-  Check voltage of motors given on the name plate with available voltage before connecting.
- Motor wires should be selected in a way that voltage drop does not exceed 5 % at full load.
- In order to prevent that water penetrates into the terminal box, close cover carefully and make sure that rubber seal fits tightly into the groove, then screw.

- Introduce cable into motor terminal box and connect control and regulation devices according to Fig. 12. All these works to be carried out carefully.

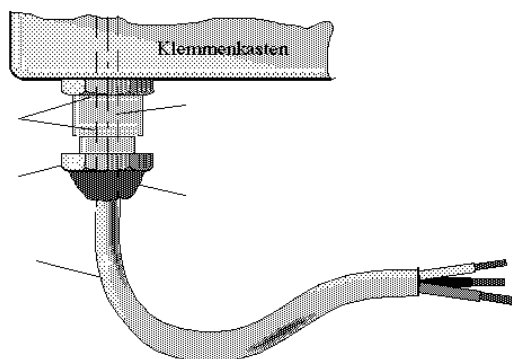

Fig. 12: Sealing of Cable Inlet at Terminal Box

5.4 Fan Motors

5.4.1 Series EWK 036ÉEWK 450

three-phase A.C. motor. Mounting position V1

Single speed Y- Δ -Connection with improved Y Δ starting connection

Multispeed Y/YY-Dahlander connection

5.4.2 Series EWK 630É1800

Geared Motor Mounting position V1

Single speed Y- Δ -Connection with improved Y Δ starting connection

Multispeed Y/YY-Dahlander connection

5.4.3 Series EWB And MODUPOL "

Geared Motor Mounting position V1

Single speed Y- Δ -Connection with improved Y Δ starting connection

Multispeed Y/YY-Dahlander connection

5.4.4 Instructions For Fan Motor Control

The electrical wiring must be carried out following the wiring diagram of Axima Refrigeration GmbH which is delivered in any case.

With two-speed motors the following points have to be observed:

- High-speed stage is always switched-on through low-speed stage. By a time- delay relay high-speed will be switched on when the low speed range is reached. (Adjustment range approx. 5 to 30 sec.).
- By switching over from high-speed stage to low-speed stage it should be avoided that sudden mechanical braking overstrains fan blades, bearings and supports. Therefore, switching over from high-speed to low-speed is carried out by means of a time-delay relay.



Time lag should be set in such a way that once the motor is switched-off, it continues to turn free of voltage as long as the low-speed range is reached or has fallen below it. It is only then that the contact for low-speed can be switched-on (setting range for the time-delay relay approx. 5 to 30 sec.).



General rule: Setting time for the time-delay relay can be too long, but should never be too short.

Motors have to be protected from overload by thermally delayed overload relays. Adjustment of the bimetallic relays has to be carried out according to the indications in the corresponding wiring diagram.

Motors should not switch from high to low speed or vice versa more frequently than 20 circles per day and maximum 3 to 4 times per hour.

5.5 Lubricants

The speed reducers are furnished with a filler-, oil level- and oil drain plug. Before starting operations, the separately supplied venting screw has to replace the filler plug.

In general the speed reducers are shipped with their lubricant charge, ready for operation but nevertheless a final control before start-up is recommended.

Fill quantity of standard geared motors:

Type	Fill
• EK 100	approx. 4,5 l
• ZK 101	approx. 8,3 l
• EK 120	approx. 6,7 l
• EK 140	approx. 14,1 l
• ZK 120/121	approx. 18,0 l
• EF 125 K	approx. 4,0 l
• EF 140 K	approx. 5,5 l
• 143 DFN	approx. 28,0 l
• 92 DFN	approx. 6,0 l
• 112 DFN	approx. 10,6 l
• ZK 141/142	approx. 30,0 l
• ZK 161/162	approx. 32,0 l
• ZK 181	approx. 64,0 l

If other brands of geared motors are used, ask the manufacturer for corresponding operating instructions.

5.6 Recommended Lubricant Quality

Minimum Requirements:

lubricant group	114
ISO VG	220 cSt at 40 °C
E/50°C	16

Only blended , age resistant and non-foaming EP oils should be used. Do not mix oils of different manufacturers

5.7 Disposal Of Used Oil

It should be kept separately from other waste oils and be disposed of according to the local regulations.

6. Initial and Seasonal Start-Up

Before initial start-up or after a long shut-down period, the unit should be thoroughly inspected and cleaned.

- Turn the fan by hand to ensure rotation without obstruction.
- Start the fan and check for the proper rotation as indicated by the arrow on the motor.
- Adjust overload fuses to nominal current according to name plate.
- Check current consumption of each phase and compare with indications on motor name plate.
- Once the pump is in operation, check inlet pressure at the water distribution of the cooling tower. In order to obtain the guaranteed cooling capacity, the pressure must comply with the required head pressure (see name plate/ order confirmation) at the nozzle. Pump to be started against closed valve.



The maximum pressure must not exceed 0,7 bar, a minimum pressure of 0,2 bar is needed for proper function.

- Adjust water level in water collecting basin of cooling tower or intermediate water container. Secure make-up water supply. Water regulation can be ensured either by a float valve or other devices. Adjust water level, so that suction bend to pump is sufficiently covered by water to avoid eddies and consequently the suction of air.
- Furthermore, you should bear in mind that when stopping the pump there is still some water flowing into the basin. Therefore the maximum water level should always be fixed underneath the overflow.
- Adjustment of blow-down (see point 7.1.3).
 - a) Blow-down can be carried out either continuously or in regular intervals by means of a hand valve whereby the drained water quantity is manually measured. With small plants, this method is quite appropriate.
 - b) With bigger plants, blow-down is generally carried out automatically by means of a conductivity measuring unit.

7. Maintenance Schedule

7.1 Maintenance Schedule For EWK-Series

Maintenance intervals	Drive	Fan	Cooling fill	Louvers at air inlet	Strainer basket	Float valve level control	Water spray nozzles
After 500h or monthly					Check contamination level, clean if need be	Check operability, clean if need be	
After 1000h or at least quarterly	Control oil level at geared motor	Check if fixing bolts at blades fit properly	Check contamination, control algae if need be	Check contamination level, clean if need be			
After 8000h or annually	Check fixings. Oil change with geared motor	Check impeller of damages and contamination, clean if need be. Check fixings	Check contamination, clean if need be				Check performance
After approx. 30000 h at least every 4 years	Regrease bearing renew fat supply if need be						

7.2 Maintenance Schedule For EWB And MODUPOL " Series

Maintenance intervals	Geared motor	Fan	Cooling fill	Louvers at air inlet	Strainer basket	Float valve level control	Water spray nozzles
After 500h or monthly					Check contamination level clean if need be	Check operability clean if need be	
After 1000h or at least quarterly	Control oil level	Check if fixing bolts at blades fit properly	Check contamination control algae if need be	Check contamination level clean if need be			
After 6000h or annually	Check fixings. Oil change	Check impeller of damages and contamination clean if need be. Check fixings	Check contamination clean if need be				Check performance
After approx. 16000h at least every 2 years	Check bearings renew if need be						
After approx. 20000 hr at least every 3 years	Lubricate E-motor bearings renew fat supply if need be						

7.3 Instructions For Maintenance Work

Maintenance work	Cooling tower type	Carrying-out
Oil change only with heated motor)	EWK 630E1800	Install oil collecting basin Open oil drain and filler screw, drain oil. Close drain screw before filling. Fill in oil and close filler screw
	EWB 1300-200 and MODUPOL EWK 2100-000	<p>Possibility I: oil change with pump out Recommended pump: barrel pump with pipe connection R 1/2. Pump is inserted into boring for measuring stick. With DFN gears 60% of the oil is renewed. The following intervals have to be observed for partial oil change: first oil change after 6000 operating hours then every 3000 operating hours after 21000 operating hours Complete oil change, change of bearings and gaskets</p> <p>Possibility II: oil change with motor test The complete fan unit is dismantled, the fan impeller is lifted off the gear shaft and the supporting unit of the fan unit is unscrewed. The gear is put aside and the oil is drained through the lateral drain screw. Before refilling the gear is washed with winding oil. For geared motors with force-feed lubrication see special regulations</p>
Control of cooling fill	All cooling towers EWK 036-800 MODUPOL EWK 2100-9000 EWB 1300-7200	<p>In extreme, deposits in the cooling fill (e.g. iron slurry from pipes, furring, algae) can result in overload and thus cause the destruction of the cooling tower. With clogged cooling fill the refrigeration effect decreases.</p> <p>Control of lower side of cooling fill through dismantling of the air inlet louver to see if there are algae or deposits. Control of upper side through inspection glasses (remove if polluted) or inspection hatch, with EWB cooling towers wall plates can be dismantled.</p> <p>If cleaning is necessary, charge warm water connection with cleaning solvent (engage expert company if need be). In extreme, remove cooling fill for cleaning or exchange.</p> <p>Do not clean with high pressure cleaner from short distances as the fill material could be damaged</p>
Functional test of nozzles	EWK 036-1800 MODUPOL EWK 2100-9000 EWB 1300-7200	With clogged or damaged nozzle the spraying inside the water basin is irregular and the danger of damaging the fill material occurs. Also the cooling capacity is limited.

8. Water Quality

The water composition has a special importance for the cooling tower operation. It has an influence on the heat exchange capacity, the service life and profitableness of the cooling tower. It is therefore recommended to get a water analysis made already in the period of planning or at least before initial start-up into operation, and if necessary to get the advice of a specialist for water treatment.

Here in this setting we cannot but give you some general information.

8.1 Required Make-Up Water Rate

The total make-up water rate comprises water loss by evaporation, splash and drift, blow-down and plant-conditioned leakages.

$$m_{wZ} = m_{wV} + m_{wS} + m_{wA} + m_{wL}$$

where:

m_{wZ} make-up water rate

m_{wV} evaporation loss

m_{wS} splash- and drift loss

m_{wA} blow-down

m_{wL} losses by plant-conditioned leakages

8.1.1 Evaporation Loss

Evaporation loss depends on the cooling capacity and the atmospheric conditions. An exact calculation can be made if operation conditions are known. In most cases, for an approximate estimation the following simplified calculation is sufficient.

The simplified method of calculation of the evaporation loss m_{wV} is as follows:

$$m_{wV} = \frac{m_w (t_{w1} - t_{w2})}{600} \left[\frac{m^3}{h} \right]$$

m_w = water flow to be cooled [m^3/h]

t_{w1} = water temperature at inlet [$^{\circ}C$]

t_{w2} = water temperature at outlet [$^{\circ}C$]

8.1.2 Splash- And Drift Loss

This occurs mostly at the air discharge of the fluid cooler. Due to the highly efficient drift eliminator, it is generally less than 0,1 % of the spray water flow rate. Splash loss at the air intake is in general of the same dimension.

8.1.3 Blow-Down

In order to avoid a too high concentration of dissolved solids in the circulating water a part of the water circuit has to be drained continuously. The bleed-off water quantity depends on the quality of the circulating water and of the make-up water. If the carbonate hardness (or chlorides content, minerals content) is taken as criterion, the bleed-off water quantity can be calculated as follows:

$$m_{wa} = \frac{m_{wV}}{E - 1}$$

E = Concentration Factor

$$E = \frac{KH_U}{KH_Z}$$

KH_U = carbonate hardness of the circulating water

KH_Z = carbonate hardness of the make-up water

The concentration factor should not be smaller than $E= 3...4$, as at smaller values the blow-down rate and consequently the necessary fresh water quantity will increase considerably.

For calculation see also Fig 7: 'Water Concentration'

8.1.4 Leakage Loss

This is a point conditioned by each particular plant and cannot be estimated by the cooling tower supplier.

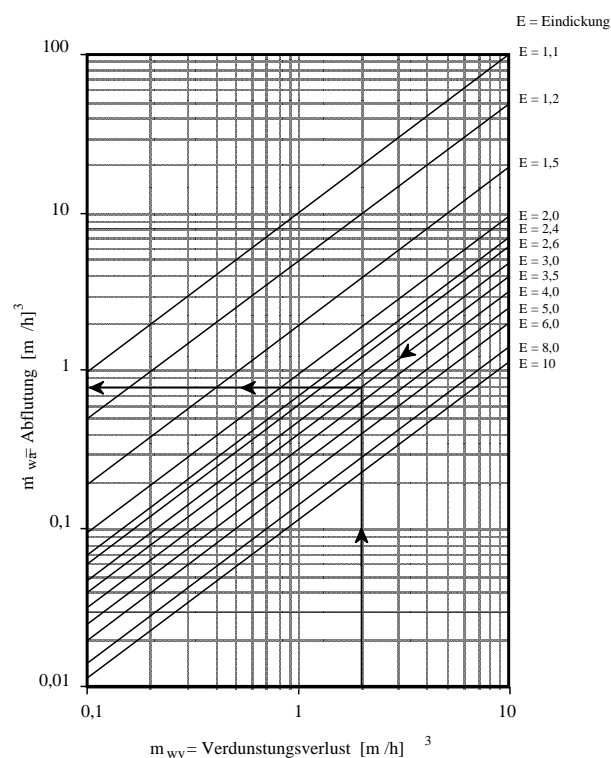

Fig.13: Calculation of bleed-off m_{wa} depending on water concentration factor E and evaporation loss m_{wv}

Example:

$$m_{wv} = 2 \text{ m}^3/\text{h}, E = 3,5 \rightarrow m_{wa} = 0,8 \text{ m}^3/\text{h}.$$

8.2 Circulated Water Quality Guidelines

For optimal efficiency and maximum equipment life, the quality of the recirculating water should be within the limit values of table shown below.

See also VDI 3803 Bl. 10 for further information.

Carbonate Hardness	7 - 9	°dH
Carbonate Hardness with the Addition of Stabilizers	bis 20	°dH
Chlorides Content approx.	300	mg/l
• in case of Austenitic Steels approx.	50	mg/l
pH-Value	7 - 8	
for Light Metals	7 - 7,5	
Sulphates Content approx.	500	mg/l
Iron approx.	0,3	mg/l
Total Minerals Content	2000	mg/l
Suspended Substances approx.	50	mg/l
Conductivity	1200	µS/cm

9. Trouble Shooting

Operation Type of trouble	Preventive measures Trouble-shooting
Winter operation danger of freezing	<ol style="list-style-type: none"> 1. Never operate cooling tower without heat load (never run fan without cooling water feed). 2. Water temperature should be as high as possible (usually not lower than 10°C; thermostatic fan control). 3. Drain all outdoor pipes during plant standstill 4. Avoid ambient freezing. Run fan at low speed (with pole-changing motors) or switch off. 5. Remove formation of ice from the air inlet louvres by switching off the cooling tower fan and charging the cooling tower only with warm water. Do not remove ice layer forcibly as damages may occur. 6. Cold water outlet can be kept free of ice through installation of a heating. Inform maintenance personnel before beginning of frosty weather.
Vibrations	<ol style="list-style-type: none"> 1. Check fan blades for damages and pollution and clean if need be. 2. Check if correct seat of fan blades is guaranteed (placing of blades, fixing screws, pitch angle). 3. Check if water outlets are clogged in hub plate or fan blade 4. Make sure that there is no formation of ice at the impeller during frosty weather, otherwise heavy unbalance or strong damages are possible.
Cooling capacity is not sufficient	<ol style="list-style-type: none"> 1. Check direction of fan rotation. 2. Check water distribution nozzles 3. Check if cooling fill is clogged. Polluted fill material can cause overload of cooling tower.
Furring inside cooling tower or piping system.	<p>Permitted water hardness is exceeded</p> <ol style="list-style-type: none"> 1. Check if sufficient water is drained - also see chapter 8.1.3 2. Have made a water analysis and carry-out water treatment 3. Remove furring with lime dissolvent (ask expert company), finally neutralize plant.
Algal or slimy control	<ol style="list-style-type: none"> 1. Add acid to reduce pH-value 2. Treat water with biocides. Carry out biocide treatment in batches, change biocides after longer treatment (ask expert company).
Corrosion	<ol style="list-style-type: none"> 1. Make water analysis and water treatment according to the instructions of the expert company. 2. If pH-value control available, check electrodes, remove deposits if necessary, then calibrate. 3. Avoid combination of copper/galvanized steel in the water circuit. 4. If make-up water is decarbonized, let it flow from above the cooling fill to expel free CO₂ <p>If chloride content is >50mg/l austenitic steel can develop corrosion, especially with stagnant water, avoid tanks of austenitic steel. (Be especially careful with weldings).</p>
Damages of concrete basin	Sulphate content too high. Line basin with plastic material.
Noticable noises at gears	<ol style="list-style-type: none"> 1. Check oil level, refill oil if need be. 2. Check shift frequency with automatic operation and limit to 3...4/h. Increase shift difference at thermostat if need be. 3. With pole-changing motors adjust time relay to min. 30 seconds for change-over from high to low speed.

9.1 Cleaning

The table shown below illustrates the main elements of a maintenance schedule for the proper control of a circulating water system.

Description of Service	Start-Up	Weekly	Monthly	Every Six Month	Shut-Down	Annually
Inspect general conditions of unit	X	X			X	
Clean debris from unit	X		X		X	
Inspect sump-clean and flush if required	X			X		
Clean sump strainer	X		X			
Check and adjust sump water level and make-up	X		X			
Inspect fill for fouling	X		X			
Inspect water distribution	X		X			
Check drift eliminator	X	X				
Check water quality against guidelines	X	X				
Check chemical feed equipment	X	X				
Check and adjust bleed rate	X	X				
Check pan heaters and accessories			X			
Drain sump and piping					X	
Inspect protective finish						X

Material		max. Temp.	pH-value
cooling fill of	PVC	60 °C	6,5...8,5
“	modified PVC	80 °C	6,5...8,5
“	polypropylene	80 °C	6,5...8,5
“	polystyrene (unstable against hydrocarbons)	65 °C	6...10
drift eliminator of	PVC	60 °C	6,5...8,5
“	modified PVC	80 °C	6,5...8,5

10. Safety Regulations

10.1 Welding and Grinding Works

By carrying out welding and grinding works, fire hazard of plastic parts. Therefore, the following precautions have to be taken:

- a) see that a foam fire-extinguisher is at hand.
- b) cover the upper air opening of the fluid cooler to avoid air currents.

In case of explosion hazardous surroundings, the local protective measures have to be observed.

Keep explosion protection prescriptions.



BE CAREFUL WITH OPEN FIRE IN THE VICINITY OF THE COOLING TOWER

10.2 Access Inside the Cooling tower

If work has to be carried out inside the tower, make sure that main switch is cut out. A well legible panel has to be put at the main switch with the following wording:



DO NOT SWITCH ON, DANGER OF LIFE !

10.3 Water Connections

According to health regulations for water hygiene (see DIN 1988), water pipes for water for general use and for drinking water can only be connected, if a specially designed pipe separator (DVGW tested and authorized) is used.

Local regulations may supersede German regulations.

11. Resistance

The details concerning material resistance only refer to the most important data. If there are special substances in the water, which can cause destruction, please contact us.

Depending on the application also other suitable materials can be used

