



## **OPERATING AND MAINTENANCE INSTRUCTIONS FOR COOLING TOWERS EWK – D (A) TYPE**

<b>TABLE OF CONTENT.....</b>	<b>PAGE</b>
1 INTRODUCTION.....	2
2 OPERATION.....	2
3 GENERAL DESCRIPTION.....	3
4 SPECIAL EQUIPMENT.....	5
5 INSTALLATION.....	8
6 INITIAL AND SEASONAL START – UP.....	10
7 MAINTENANCE SCHEDULE.....	11
8 WATER QUALITY.....	14
9 TROUBLE SHOOTING.....	18
10 SAFETY REGULATIONS.....	19
11 RESISTANCE.....	19

## 1 Introduction

This operating instruction is published as a guide for installing, operating and maintenance of mechanical draught industrial cooling towers. Following these guidelines ensures a optimum performance and maximum service life of the equipment.

If the instructions laid down in this guide are not observed, the manufacturer cannot be held responsible in case of damage.

The general conditions of supply of EWK which are an integral part of the order confirmation – are respectively effective.

For technical details please refer to our order confirmation.

Subject to technical modifications.

### For your kind attention:



This guide is in the first place intended for the operating staff and should always be available. Its contents should be dealt with confidentially.

The copyright remains the property of EWK.

We draw your attention to the fact that it is quite impossible to treat herein all probabilities. This means that the user is not exempted of the usual responsibilities connected with the use of technical machinery. It is, therefore, taken as granted that the operating staff is well instructed and knows how to handle this installation.

No claims whatsoever could be enforced by the contents of this guide.

If the user has no operational manual of his own, all maintenance and repair work could be recorded on page 21 of this guide.

## 2 Operation

Cooling towers of type EWK – D(A) are mechanical draught series type cooling towers working in counter flow principle.

In this type of cooling tower the water to be cooled is distributed evenly over a packing, which is ventilated from below with air. Inside this packing heat and mass transfer takes place. The partial evaporation of water reduces the heat from the water circuit and transmits it to the air. Compared to dry coolers, with type of wet cooling towers a lower water temperature can be achieved even in case of high air temperatures.

**3 General Description**

**3.1 Cooling Tower**

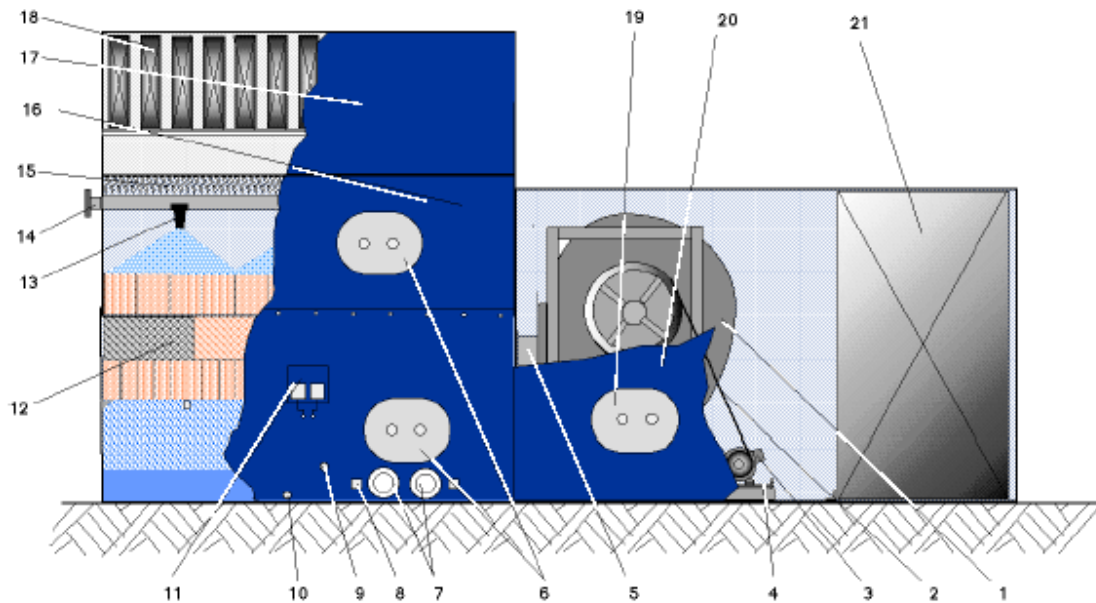

**Fig. 1** Series cooling tower with torced fan arrangement, type EWK-D

**Legend:**

- |                               |                                |
|-------------------------------|--------------------------------|
| 1 Fan                         | 12 Packing                     |
| 2 V- Belt Drive               | 13 Water Distribution Nozzles  |
| 3 Fan Motor                   | 14 Water Inlet Connection      |
| 4 Motor Basic Plate           | 15 Drift Eliminator            |
| 5 Fan Discharge               | 16 Casing                      |
| 6 Access Hatch                | 17 Silencer for Air Discharge  |
| 7 Water Outlet Connection     | 18 Baffles Air Discharge       |
| 8 Electrical Immersion Heater | 19 Access Hatch to Belt Drive  |
| 9 Overflow and Flota Valve    | 20 Air Inlet Silencing Chamber |
| 10 Draining Plug              | 21 Baffles Air Inlet           |
| 11 Thermostat                 |                                |

The cooling tower casing and the water basin are made of strong corrosion-proof fibreglass reinforced poliéster resin. The water basin is an integrated part of the cooling tower casing, on this reason leakage is prevented.

For the examination of the spray nozzles and for maintenance on the adjustable flota valve inspection hatches are provided.

## **3.2 Hydraulic Part**

### **3.2.1 Water Distribution System**

The water flows through the main distribution pipes made of stainless steel to the plastic nozzles. Their arrangement allows an optimum water distribution inside the tower.

### **3.2.2 Packing**

The packing consists of some layers of a high performance cooling tower fill, made of long lasting plastic material. For standard applications a film type fill is built in, splash fill is also available upon request.

(Standard:PVC; execution see order confirmation)

### **3.2.3 Drift Eliminator**

In order to reduce water losses, a drift eliminator is installed above the water distribution system. It consists of individual packages put side by side. The specially Developer profile form provides a low pressure loss and a high eliminating effect.

## **3.3 Mechanical Part**

### **3.3.1 Fan**

Escher Wyss cooling towers of the EWK – D (A) series are equipped with low noise radial fans at air intake side. The fan blows the recommended air through the tower.

### **3.3.2 Fan Drive**

Three phase squirrel cage motors made in Western Europe are used. The rotational speed is 750/1.500 min.<sup>-1</sup>, type of construction B3, protection class IP54 or IP55 depending on site conditions for cooling towers, following IEC-Standard, protected against corrosion by priming and top coat.

Power transmission through V-belt drive. The V-belt pulleys are made of cast iron. The safety protection of the V-belt drive can easily be removed for maintenance purposes.

Cooling towers of EWK-D (A) type do not contain distinct protection for V-belt drive, since it is protected by the casing of the noise attenuator.

**3.3.3 Flexible Connection**

The fan outlet section can be connected with a flexible channel to the cooling tower casing, this is recommended for low noise or low vibration execution of the cooling tower since the flexible connection prevents propagation of structure borne noise via cooling tower casing.

**3.4 Strainer Basket**

The strainer prevents that coarse impurities enter into the cooling water circuit. It can be installed either in the water basin of the cooling tower or in a separate.

## **4 Special Equipment**

### **4.1 Float Valve**

A float valve is used for the regulation of the make-up water, it is installed in the cooling tower basin or in a temporary storage basin. The water level has to be regulated in that way that the drain piece is sufficiently covered with water and that whirlpools and air suction can be avoided.

When adjusting the water level it has to be considered that there is always a small quantity of water flowing back into the basin when switching off the cooling tower pump. Water should not drain off through the overflow. The maximum water level must therefore always remain below the overflow level.

### **4.2 Level Control**

#### **4.2.1 Electrode Level Control**

It is possible to regulate the make-up water inlet by using an electrode level control with solenoid valve, for greater water flow rates with motor valve.

To operate the solenoid or motor valve the following is necessary:

- \_ 1 electrode relay
- \_ 3 electrodes (max./min./max.)
- \_ 1 terminal box for electrodes' cable

#### **4.2.2 Electrical Float Valve**

A solenoid valve or motor valve is controlled by the level of a swimming body on the water surface.

#### **4.2.3 Hydrostatic Level Control**

The hydrostatic pressure in the water basin is measured by a capacitive pressure gauge. Its signal can be used for control of solenoid valve or motor valve.

### **4.3 Protección anti- hielo**

To keep the area near run-off pipe ice-free during operation at cold weather conditions an electrical immersion heater is available.

The immersion heater shall be connected according to the wiring diagram which is delivered in any case by EWK.

The heating must not be switched on, when water level in basin is too low. Overheat protection device is therefore available.

#### **4.4 Fan Thermostats**

The fan thermostats serve to switch on or off the fan drives depending on the cold water temperature. The sensor is preferably placed in the piping for cooled water and should be protected by a threaded sensor cartridge. The sensor may also be placed in the cooling tower basin but it has to be taken into account that mechanical stress and vibrations to the sensor are to be avoided. For precise measurement of the water temperature it is important that sensor is completely covered by the water.

The sensor is delivered as separate part.

#### 4.4.1 One-Stage Fan Thermostat, RT 26

Range -5 to +50° C (Can also be used as heating thermostat)

This device is equipped with a switch-over contact. If used as a fan thermostat, connected to terminals 2 and 3, as heating thermostat it should be connected to terminals 2 and 1.

It is supplied for the heating control with the temperature setting:

- Switching on at 1,0 ° C and
- Off at 3,5 ° C

If used as a fan thermostat, the required switching points have to be set according to the enclosed directions, for example:

Switching on at 26,0 ° C and

Off at 22,0 ° C.

The lower temperature has to be set by means of a control button. The switch difference is set on the differential roll.

The upper response temperature results from the lower response temperature + difference which, for the cosen example is

$$22 + 4 = 26^{\circ} \text{ C}$$

Do not chose too small a switch difference, in order to avoid that motor wetches on and off too frequently. The cold water temperature should not be fixed lower than 10° C

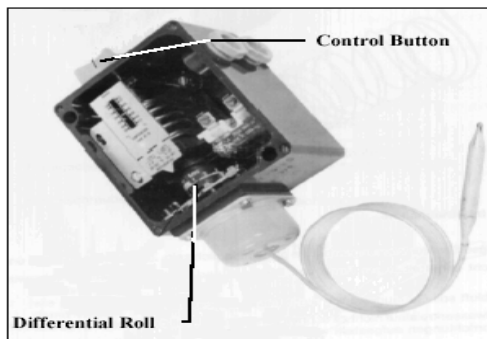

Fig. 2 One-stage thermostat RT 26

#### 4.4.2 Two-Stage Thermostat, A 28 MA

For two-speed fan motors two-stage thermostats must be used. This device is equipped with two switch contacts (switch blocks):

- low temperature range, right hand switch block.
- high temperature range, left hand switch block.

For fan operation, connect it at the red and white marked terminals respectively. The bridge between the red marked terminals has to be eliminated.

Range +5...+5° C

Difference in the stages 3K, difference between the stages approx. 4K

Example:



The switching-on temperature in the first stage (in this case +25 °C) has to be set on the graduation. All other switching points result from the set differences in and between the stages.

If using other thermostat types, the settings and connections have to be carried out according to the corresponding instructions.



Fig.3 Two-stage thermostat A28 MA

#### **4.5 Sound Attenuator Air Discharge**

The sound attenuator at the air discharge is carried out with parallel arranged sound absorbing elements. In most cases its noise absorption factor is sufficient to reach required noise level. The casing is made of fibreglass reinforced polyester.

#### **4.6 Sound Attenuator Air Inlet Side**

At the air inlet side, sound attenuator casings of fibreglass reinforced poliéster can be adapted. Sound attenuation is obtained by baffles with moisture resistant absorption material.

#### **4.7 Water Distribution Pipe**

For cooling towers having multiple water pipe connectors a pre-distribution device is available to reduce the number of connectors.

### **5 Installation**

#### **5.1 Place of Installation:**

- Installation has to be carried out according to our foundation drawings.
- The place of installation should allow an easy access to all parts of the cooling tower. Free air flow to air inlet and outlet should be given.
- Avoid installation directly at the edge of roofs and near public roads; possibility of mist and ice formation in winter.
- Contact of moist air with walls and buildings should be avoided.
- In order to keep the cooling water circuit clean as long as possible, do not install the cooling tower near trees or exhaust devices.

#### **5.2 Electric Installation**

- All information given on the wiring diagram supplied with our order confirmation has to be observed. All protective measures have to be carried out according to the safety regulations applicable on site.
- Check voltage of motors given on the name plate with available voltage before connecting.
- Motor wires should be selected in a way that voltaje drop does not exceed 5% at full load.
- In order to prevent that water penetrates into the Terminal box, close cover carefully and make sure that rubber seal fits tightly into the groove, then screw.
- Introduce cable into motor Terminal box and connect control and regulation devices according to Fig. 4. All these works to be carried out carefully.

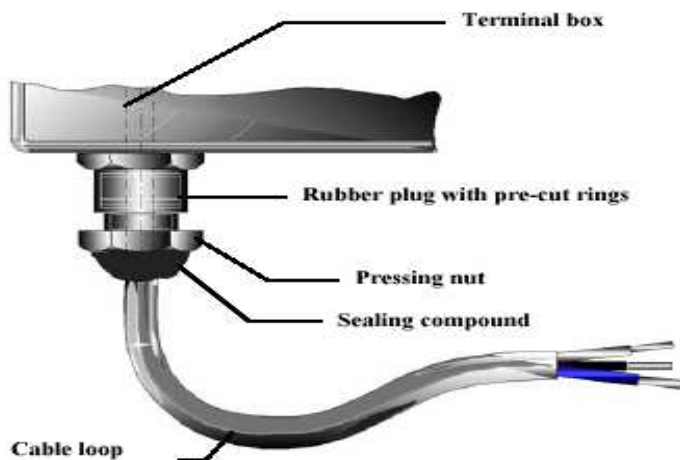



**Fig.4 Sealing of Cable Inlet at Terminal Box**

### 5.3 Instructions for Fan Motors

The electrical wiring must be carried out according to the wiring diagram of EWK- which is delivered in any case.

UIT two-speed motors the following points have to be observed:

-  High-speed stage is always switched-on through low-speed stage. By means of a time- delay relay high-speed will be switched on when the low speed range is reached. (Adjustment range approx. 5 to 30 sec.).
-  By switching over from high-speed stage to low-speed stage it should be avoided that sudden mechanical braking overstrains fan, bearings and supports. Therefore, switching over from high-speed to low-speed must be carried out by means of a time-delay relay.

Time lag should be set in such a way that once the motor is switched-off, it continues to turn free of voltage as long as the low-speed range is reached or has fallen below it. It is only then that the contact for low-speed can be switched-on (setting range for the time-delay relay approx. 5 to 30 sec.).



**General rule: Setting time for the time-delay relay can be too long, but should never be too short.**

Motors have to be protected from overload by thermally delayed overload relays. Adjustment of the bimetallic relays has to be carried out according to the indications in the corresponding wiring diagram.

Motors should not switch from high to low speed or vice versa more frequently than 20 circles per day and maximum 3 to 4 times per hour.

## 6 Initial and Seasonal Start-Up

Before initial Start-up or after a long shut-down period, the unit should be thoroughly inspected and cleaned.

- Turn the fan manually in order to ensure rotation without obstruction.
- Start the fan and check for the proper rotation as indicated by the arrow on the motor.
- Adjust overload fuses to nominal current according to name plate.
- Check current consumption of each phase and compare with indications on motor name plate.
- Once the pump is in operation, check inlet pressure at the water distribution of the cooling tower. In order to obtain the guaranteed cooling capacity, the pressure must comply with the required head pressure (see name plate/ order confirmation) at the nozzle. Pump to be started against closed valve. The maximum pressure must not exceed 0,7 bar, a minimum pressure of 0,2 bar is required for proper function.
- Adjust water level in water collecting basin of cooling tower. Secure make-up water supply. Water regulation can be ensured either by a float valve or other devices. Adjust water level, so that suction bend to pump is sufficiently covered by water to avoid eddies and consequently the suction of air.
- Furthermore, you should bear in mind that when stopping the pump there is still some water flowing into the basin. Therefore the maximum water level should always be fixed underneath the overflow.
- Adjustment of blow-down (see point 8.1.3).

a) Blow-down can be carried out either continuously or in regular intervals by means of a hand valve whereby the drained water quantity is manually measured. With small plants, this method is quite appropriate.

b) For bigger plants, blow-down is generally carried out automatically by means of a conductivity measuring unit.

**7 Maintenance Schedule**

	<b>Stara-up Also seasonal</b>	<b>Every week</b>	<b>monthly</b>	<b>Every six month</b>	<b>Shutdo wn</b>	<b>Annual ly</b>
<b>Motor:</b> Check current and voltaje Check fixing	<b>X</b> <b>X</b>					<b>X</b>
<b>V-belt drive:</b> Check belt tension and adjust when necessary	<b>X</b> <b>(after 4 h.)</b>		<b>X</b>			
<b>Fan:</b> Check for deposits on blades check fixing Grease bearings	<b>X</b>			<b>X</b> <b>X</b> <b>X</b>	<b>X</b>	
<b>Spray nozzles:</b>  Check spray pattern by sight Check head pressure	<b>X</b> <b>X</b>		<b>X</b>	<b>X</b>		
<b>Fill:</b> Check for deposits, Clean when necessary				<b>X</b>	<b>X</b>	
<b>Strainer:</b> Check for clgging Clean if necessary	<b>X</b>	<b>X</b>	<b>X</b>		<b>X</b>	
<b>Water basin:</b> Check for deposits Clean when necessary	<b>X</b>			<b>X</b>	<b>X</b>	
<b>Blow- down:</b> Check and adjust. Check function.	<b>X</b> <b>X</b>		<b>X</b>			

## 7.1 Instructions For Maintenance work

### 7.1.1 Fan shaft bearing

The fan shaft is supported at each end by a self-aligning Soller bearing, each equipped with a lubrication fitting. The bearing life is calculated for 20000 hrs. under normal operating conditions. The bearings are lubricated with age-resistant high quality grease.

When lubricating during operation time, gradually add the advised quantum grease to the bearing.



**You must not touch rotating parts or remove protection grids. Before entering the silencer casing you must be sure that the fan motor is switched off.**

### 7.1.2 Disassembly of bearing

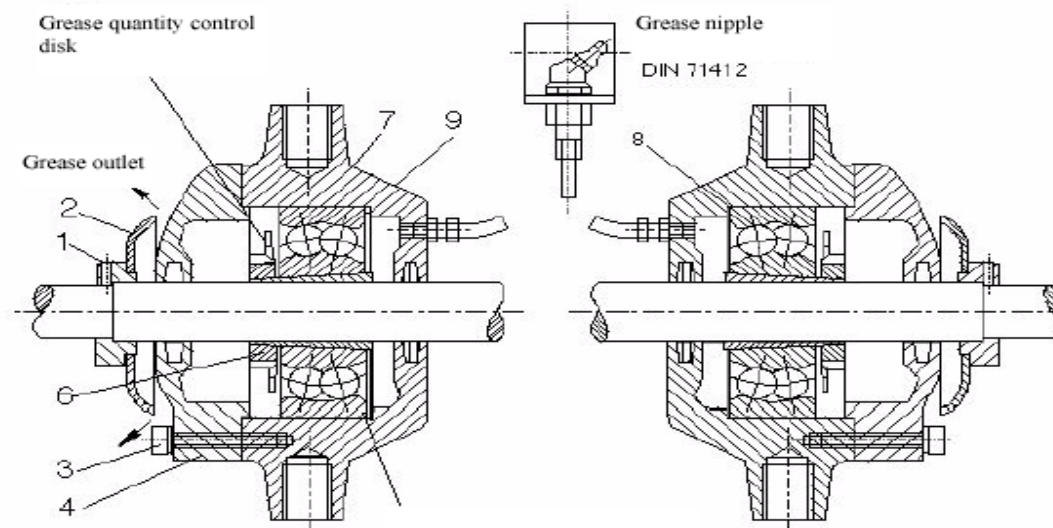

**Fig.5** Self-aligning Soller bearing.

Unscrew stud bolt 1, remove disk 2, unscrew bolt 3 and remove bearing side cover 4. unbend locking plate of sleeve nut 6 then unscrew it, leave the nut 6 on thread. A tube has to be set onto the sleeve nut and with carefully strikes the tapered-sleeve wedge bearing can be loosened.

After fixing the fan shaft, unbolt the screws of supporting rods and remove it. Now you can exchange the bearing.

The assembling is done the same way back.

### 7.1.3 Initial Lubrication

It is recommended that bearing and bearing-box are well cleaned and no deposits of old grease rests inside the shell.

First fill the self-aligning Soller bearing with grease (recommended Shell Alvania 3 or comparable), then fill 1/3 of the bearing-box with the same grease.

Fan type	Shaft Diameter	Bearing Description	Bearing type	Grease quantity per bearing for lubrication
900 1000	60	Self-aligning Soller bearing	2313 K/C3 + H2313	130 gr

**7.1.4 Fan drives.**

To properly adjust the V-belt tension, position the motor by adjusting the base plate so that a single belt will deflect the measure E, when a force of P = 50 N presses midway between the V-belt pulleys.

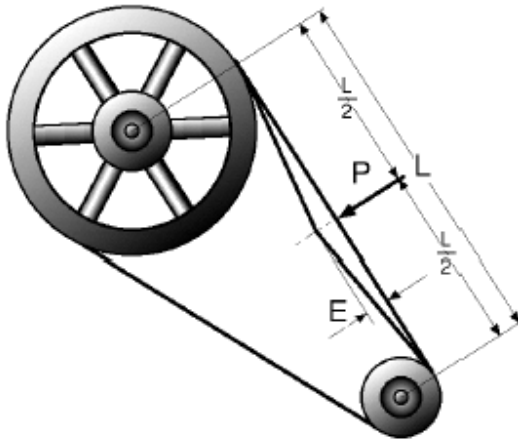

<b>Center Distance L</b>	<b>Deflection E</b>
800...1000 mm	25mm
1000..1200mm	30mm
1200..1400mm	35mm

**Fig.6** check V-belt tension



**New V-belts elongate during run-in phase; after 4 hours operational time their tension must be checked and when necessary new adjusted.**

**8 Water Quality**

The water composition has a special importance for the cooling tower operation. It has an influence on the heat exchange capacity, the service life and profitability of the cooling tower. It is therefore recommended to get a water analysis made already in the period of planning or at least before initial start-up into operation, and if necessary to get the advice of a specialist for water treatment.

Here in this setting we cannot but give you some general information.

**8.1 Required Make-Up Water Rate**

The total make-up water rate comprises water loss by evaporation, splash and drift, blow-down and plant-conditioned leakages.

$$mwz = mwv + mws + mwa + mwL$$

where:

- $m_{wz}$  make-up water rate
- $m_{wv}$  evaporation loss
- $m_{ws}$  splash – and drift loss
- $m_{wa}$  blow-down
- $m_{wL}$  losses by plant-conditioned leakages

**8.1.1 Evaporation Loss**

Evaporation loss depends on the cooling capacity and the atmospheric conditions. An exact calculation can be made if operation conditions are known. In most cases, for an approximate estimation the following simplified calculation is sufficient.

The simplified method of calculation of the evaporation loss  $m_{wv}$  is as follows:

$$\dot{m}_{wv} = \frac{\dot{m}_w(t_{w1} - t_{w2})}{600} \left[ \frac{m^3}{h} \right]$$

where:

- $M_w$  = water to be cooled (m<sup>3</sup>/h)
- $T_{w1}$  = water temperatura at cooling tower inlet (° C)
- $T_{w2}$  = water temperatura at cooling tower outlet (° C)

**8.1.2 Splash- and Drift loss**

This occurs mostly at the air discharger of the cooling tower. Due to the highly efficient drift eliminator, it is generally less than 0,1% of the spray water flow rate. Splash loss at the air intake is in general negligible.

**8.1.3 Blow-Down**

In order to avoid a tooo high concentration of dissolved solids in the circulating water, a part of the water circuit has to be drained continuously. The bleed-off water quantity depends on the quality of the circulating water and of the make-up water. If the carbonate hardness (or chlorides content, minerals content) is taken as criterion, the bleed-off water quantity can be calculated as follows:

$$\dot{m}_{wa} = \frac{\dot{m}_{wv}}{E - 1}$$

where:  $E = \text{Concentration Factor} = \frac{KHu}{KH_z}$

where: KHu = carbonate hardness of the circulating water

KHz = carbonate hardness of the make-up water

The concentration factor should not be smaller than  $E=3\dots4$ , as at smaller values the blow-down rate and consequently the necessary fresh water quantity will increase considerably.

For calculation see also Fig. 7

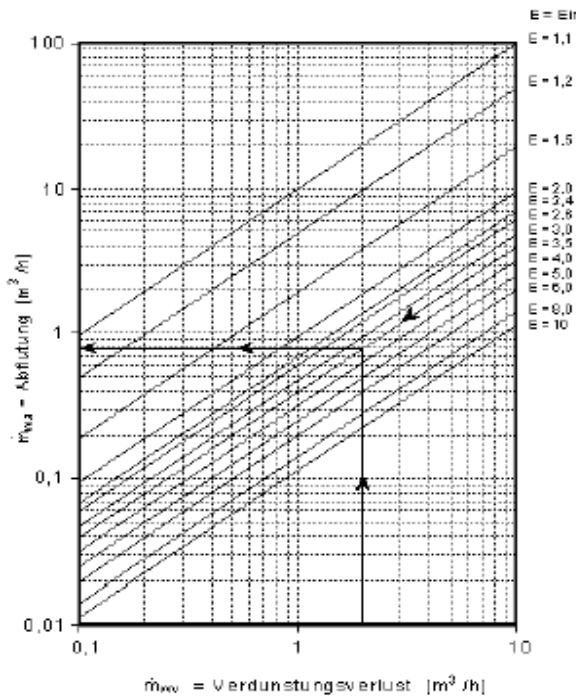

Example:

$$m_{wv} = 2 \text{ m}^3/\text{h}, E = 3,5 \rightarrow$$

$$m_{wa} = 0,8 \text{ m}^3/\text{h}$$

**8.1.4 Leakage Loss**

This is a point conditioned by each particular plant and cannot be estimated by the cooling tower supplier.

**Fig. 7** Calculation of bleed-off  $m_{wa}$  depending on water concentration factor  $E$  and evaporation loss  $m_{wv}$

## 8.2 Circulated Water Quality Guidelines

For optimal efficiency and maximum equipment life, the quality of the recirculating water should be within the limit values of table shown below.

See also VDI 3803 Bl. 10 for further information.

Carbonate Hardness	7 – 9 ° dH
Carbonate hardness with the addition of Stabilisers	up to 20° dH
Chlorides Content approx.	300 mg/l
<ul style="list-style-type: none"> <li>In case of Austenitic Steels approx .</li> </ul>	50 mg/l
pH - value	7...8
<ul style="list-style-type: none"> <li>For Light Metals</li> </ul>	7...7,5
Sulphates Content approx.	500 mg/l
Iron approx.	0,3 mg/l
Total minerals content	2000 mg/l
Suspended Substances approx	50 mg/l
Conductivity	1200 µS/c m

**8.3 Limpieza**

The table shown below illustrates the main elements of a maintenance Schedule for the proper control of a circulating water system:

Description of Service	Stara-Up	Weekly	Monthly	Every Six Month	Shut-down	Annua lly
Inspect general conditions of unit	<b>X</b>	<b>X</b>			<b>X</b>	
Clean debris from unit	<b>X</b>		<b>X</b>		<b>X</b>	
Inspect sump-clean and flush if required	<b>X</b>			<b>X</b>		
Clean sump strainer	<b>X</b>		<b>X</b>			
Check and adjust sump water level and make-up	<b>X</b>		<b>X</b>			
Inspect fill for fouling	<b>X</b>		<b>X</b>			
Inspect water distribution	<b>X</b>		<b>X</b>			
Check drift eliminator	<b>X</b>	<b>X</b>				
Check water quality against guidelines	<b>X</b>	<b>X</b>				
Check chemical feed equipment	<b>X</b>	<b>X</b>				
Check and adjust bleed rate	<b>X</b>	<b>X</b>				
Check pan heaters and accessories			<b>X</b>			
Drain sump and piping					<b>X</b>	
Inspect protective finish						<b>X</b>

**9 Localización y reparación de averías**

Kind of trouble	Possible reasons
Cooling capacity Diminished	<ul style="list-style-type: none"> <li>• Air temperature higher than assumed for design</li> <li>• Dirt and deposits in the water circuits</li> <li>• Impurities in the air ducts or ice formation</li> <li>• Air circulation is hindrance</li> <li>• Disturbances of the fan control</li> <li>• Faulty fan drive</li> <li>• Fouling in cooling tower fill</li> </ul>
No air supplied by fan	<ul style="list-style-type: none"> <li>• Motor is defective</li> <li>• Sense of rotation is not correct</li> <li>• Control defective</li> <li>• V-belt drive defective or belt tension too low</li> <li>• Air flaps closed (if available)</li> </ul>
Unusual noise	<ul style="list-style-type: none"> <li>• Bearing defect on motor or fan</li> <li>• Belt tension too low (esp. at switch on)</li> <li>• Alignment of belt pulleys is wrong</li> <li>• Faulty adjustment of time delay relay of fan motor for switching into low speed</li> <li>• Belt drive damage</li> <li>• Flexible connection between fan and casing is defective</li> </ul>
Unusual belt abrasion	<ul style="list-style-type: none"> <li>• Alignment of belt pulleys is wrong</li> <li>• Belt tension too low</li> <li>• Bushings are loose</li> <li>• Different tension of parallel working V-belts (change only belt sets)</li> <li>• To may switch off / switch on</li> </ul>
Vibrations	<ul style="list-style-type: none"> <li>• Fan Wheel is unbalanced due to dirt or damage</li> <li>• Bearing damage</li> </ul>

**10 Safety regulations**

**10.1 Welding and Grinding works**

By carrying out welding and grinding Works, FIRE hazard of plastic parts. Therefore, the following precautions have to be taken:

- a) see that a foam FIRE-extinguisher is at hand.
  - b) cover the upper air opening of the fluid cooler to avoid air current. In case of explosion hazardous surroundings, the local protective measures have to be observed.
- Keep explosion protection prescriptions.



**¡BE CAREFUL WITH OPEN FIRE IN THE VICINITY OF THE COOLING TOWER!**

**10.2 Access inside the Cooling Tower**

If work has to be carried out inside the tower or silencers, make sure that main switch is cut off. A weel legible panel has to be put at the main switch with the following wording:



**¡DO NOT SWITCH, DANGER OF LIFE!**

**10.3 Water conections**

According to healt regulations for water hygiene (see DIN 1988), water pipes for water general use and for drinking water can only be connected, if a specially designed pipe separator (DVGW tested and authorized) is used.

**11 Resistance**

The details concerning material resistance only refer to the most important data. If there are special sbstances in the water, which can cause destruction, please contact us.

Depending on the application also other suitable materials can be used

Material	Máy. Temp	pH- value
Cooling fill of PVC	60° C	6,5...8,5
“ modified PVC	80° C	6,5...8,5
“ polypropylene	80° C	6,5...8,5
“ polystyrene (unstable against hydrocarbons)	65° C	6...10
Drift eliminator of PVC	60° C	6,5...8,5
“ modified PVC	80° C	6,5...8,5

